



RELATIONS AMONG PROPOSED PREDICTORS AND OUTCOMES OF SOCIAL SELF-EFFICACY IN TURKISH LATE ADOLESCENTS

Mehmet BILGIN*

Çukurova Üniversitesi Eğitim Fakültesi Psikolojik Danışma ve Rehberlik ABD.,
Adana/TÜRKİYE

ABSTRACT

The goal of this study was to examine both the direct and indirect relations among late adolescents' social self-efficacy and their perceived parents' attitudes, attachment to parents and peers, problem-solving skills and learned resourcefulness. Two hundred and fifty five volunteer students (average age=18.5) were the participants. The Social Self-Efficacy Inventory, the Inventory of Peer Attachment and Parent Attachment, the Parents' Attitudes Inventory, the Problem-Solving Skills Inventory and the Learned Resourcefulness Inventory were administered in order to collect data. Structural equation modelling revealed that parental attachment had direct effects on social self-efficacy. In addition, authoritative parenting had indirect effects on social self-efficacy through peer attachment. The links between social self-efficacy and problem-solving skills and, between problem-solving skills and learned resourcefulness were also observed. Different model to be tested and the results showed links between parental attachment and problem-solving skills and, between social self-efficacy and learned resourcefulness.

Key Words: *Late adolescence, social self-efficacy, parental/peer attachment, perceived parental attitudes, problem-solving skills, learned resourcefulness.*

INTRODUCTION

Adolescence is a critical period during which effective beliefs in developing one's character are established. One of the skills in dealing with problems during adolescence is perceived social self-efficacy. According to Caprara, Steca, Cervone, and Artistico (2003) those with high self-efficacy experience less tension during adolescence.

Self-efficacy is one of the main concepts in Bandura's Social Cognitive Theory (Bandura, 1977). It is the sense of belief that one's actions have an effect on the environment (Steinberg, 1998). Perceived self-efficacy concerns people's belief in their capabilities to perform in ways giving them control over important events in their lives, and beliefs about efficacy form the foundation of human agency. Unless people believe that they can produce results by their actions, they have little incentive to act (Bandura, 2000). Bandura pointed out that people with high self-efficacy tend to have greater cognitive resourcefulness, strategic flexibility, and effectiveness in managing their environment, and set motivating goals for themselves. People with a low sense of self-efficacy avoid difficult tasks, considering them as threats. They typically have low aspirations and weak commitment to their goals. Bandura's (1977) influential theoretical paper on self-efficacy led to more conceptual clarity by introducing two

* **Yazar:** mbilgin@cu.edu.tr

kinds of expectations about the self: outcome expectations, which are “the person’s estimate that a given behavior will lead to certain outcomes”, and “efficacy expectations, which refer to a person’s belief “that one can successfully execute the behavior required to produce the outcomes” (p.193).

Knowledge and skill are necessary but not satisfactory for an individual’s successful behaviors. Though people are aware of what they do and when to do it, they do not always act accordingly. Self-efficacy influences a person’s behavior and the result of this behavior since self-efficacy has an important role in starting and continuing behavioral change (Bandura, 1986). Perceived self-efficacy does not show how many skills one has but determines the belief of what one can do with the help of these skills. Self-efficacy helps to harmonize with stressful conditions consisting of changing and different stimuli. In addition, it can determine whether one can accomplish a specific task, insist on solutions when faced with conflicts, use one’s competent respects and whether one charges one’s own failures into others. According to Bandura (1997), self-efficacy determines not only behavior but also mind and motivation.

Furthermore, self-efficacy is a general notion. Different self-efficacy regarding different behaviors can be named as social self-efficacy and academic self-efficacy and etc. A growing body of research has revealed the relationship between self-efficacy and social behaviors (Bandura, Barbaranelli, Caprara, and Pastorelli, 2001; Bandura, Pastorelli, Barbaranelli, and Caprara, 1999; Caprara, Regalia, and Bandura, 2002).

Social self-efficacy can be defined as one’s own perception about one’s competent responses in one’s interpersonal relationships (Bandura, 1997). According to Connolly (1989), social self-efficacy is comprised of social audacity, performance in general relationships, participation in a social group or activity, friendly attitudes and receiving and getting help from others. Relatedly, Bilgin (1996) states that social self-efficacy can be considered when one perceives oneself as an individual who can use one’s acquired skills in order to satisfactory interpersonal relationships. Gresham (1984) also claims that social self-efficacy motivates the person into social behaviors. In addition, Caprara and Steca (2005) show that social self-efficacy directly effected prosocial behavior, and Matsushima and Shiomi (2003) suggest that social self-efficacy has an effect on the reducing of interpersonal stress. It is also important that a person performs self-efficacy behaviors and these behaviors be perceived as efficient ones by older people in social self-efficacy developing (Bandura, 1986).

As for the individuals, it is important to view their transactions with their parents as an active, self-constructing process. This involves active internal representation of events and progressive construction and elaboration of personal goals, self-efficacy, and corresponding behaviors (Bandura, 1995).

There is a large body of evidence on the effects of various parenting factors and socializing styles on adolescent social competence. In one’s review on empirical studies on attachment and adolescent adjustment, Rice (1990) concluded regarding social competence that a stronger bond with parents is related to enhanced social performance. In addition, Rice, Cunningham and Young (1997) showed that both maternal and paternal attachment influenced adolescents’ competence in social situations which in turn affected their emotional adjustment. Furthermore, Malinckrodt (1992) demonstrated that paternal and maternal responsiveness were positively related to social self-efficacy. The benefits of positive parenting (being responsive, supportive and loving) concerning their children’s social competence in interactions with peers have been in the agenda of Putallaz (1987). According to Melby, Conger, Conger and Lorenz, (1993),

however, parental strictness and a lack of flexibility in rearing practice are related to deviant behavior and a disroted development of social skills of adolescents.

Establishing a person's social self-efficacy depends on the child-parent interaction, and especially increases when the child's efforts to solve one's problems on one's own are supported by parents (Corcoran, and Mallinckrodt, 2000; Giannino, and Tronick, 1988; Tronick, 1989). The first perceived of self-efficacy is gained in the family and then it develops as the child's social life enlarges and one's peer interaction increases. In some studies - conducted on parents' attitudes and adolescence behaviors- it is observed that as the relationship between the child and the parents increases positively, the child becomes more autonomous and more encouraged in establishing relationships outside one's own family (Bretherton, Golby, and Cha, 1997; De Wolf, and Van Ijzendoorn, 1997; Field, Diego, and Sanders, 2002). Thus, different family attitudes are effective in gaining self-efficacy. Parents' attitudes towards the child determine how much of one's own social capacity the child can make use of. To illustrate; more protective parents may damage the development of their child's social capacity, whereas authoritative parenting supporting child-parent attachment may encourage the child to develop one's skills, which enable the child to get to know oneself more rapidly and to feel independent (Karavalis, Doyle, and Markiewicz, 2003). The more independent socially the individual becomes the higher self-efficacy they will have. Parents can help their children to increase their self-efficacy through opportunities they have provided and authoritative parenting attitude towards their failures (Bandura, 1986).

A growing amount of research has pointed out that authoritative parenting has a facilitative role in interpersonal relationships (Baumrind, 1971; 1991; Dekovic, and Meeus, 1997; Lamborn, Mounts, Steinberg, and Dornbusch, 1991; Maccoby, and Martin, 1983; Parish, and McCluskey, 1992; Steinberg, Lamborn, Dornbusch, and Darling, 1992; Steinberg, Darling, Fletcher, Brown, and Dornbusch, 1995). Children brought up by authoritarian parents show less behavior problems but they experience more internalized distress. Furthmore, authoritarian parents have negative influences on social adaptation (Baumrind, 1971; Isabella, 1993; Kobak, and Screey, 1988; Lamborn et al., 1991; Stevenson-Hinde, and Shouldice, 1995; Steinberg et al., 1995; Young-blade, and Belsky, 1990).

Parents' attitudes are also effective in establishing children's attachment and independency balance. They determine to what extent the attachment relationship would be (Bowlby, 1969). A positive relationship between authoritative parenting and secure attachment is obvious (Baumrind, 1991; Karavalis et al., 2003; Lamborn et al., 1991; Strayer, and Preece, 1999). A positive relationship between negligent parenting and solicitous/avoidance attachment has also, been observed, whereas a negative relationship between authoritative parenting and solicitous/avoidance attachment has been observed (Karavalis et al., 2003; Strayer, and Preece, 1999).

The type of attachment to parents is vital to an individual's interpersonal relationships (Bartholomew, and Horowitz, 1991; Crittenden, 1992; Hazan, and Shaver, 1994). Corcoran and Mallinckroth (2000) have also pointed out the relationship between the social self-efficacy and parent attachment. According to Arbano and Power (2003) adolescents who are securely attached to their parents have a high social self-efficacy. In addition, Coleman (2003) has found out meaningful relationships between students' attachment to their parents and their social self-efficacy. Coleman (2003) has also stated that as social self-efficacy score decreases, attachment to both parents and peers rises. As pointed out by Lempers and Clark-Lempers (1992) peer attachment is significantly correlated with social relationship. Hazan, and Shaver (1987), Feeney, and Noller (1990) have illusrated a positive relationship between secure

attachment and romantic relationships. Solicitous attachment, however, negatively effects interpersonal relationships.

Lieberman, Doyle, and Markiewicz (1999) have shown on the other hand that as the conflicts between adolescent and family decrease, the quality of the adolescent's relationships with his friends increases. MacDonald (1998) has considered the indirect effect of adolescent-family relationships on the adolescent's relationships with his friends. According to Corcoran, and Mallinckroth (2000), Howard, and Medway (2004), and Steward, Murray, Fitzgerald, Neil, Fear, and Hill (1998) people, securely attached to their families, are compatible in their interpersonal relationships. Children whose parents are using passive problem-solving skills have solicitous attachment style (Greenberger, and McLaughlin, 1998; Harvey, and Byrd, 2000). Furthermore, Bowlby (1969) and Bretherton (1985) have studied the connection between attachment and problem-solving skills.

Considering the findings of the related studies, it can be assumed that there is a close relationship between attitudes of the parents, parental attachment, attachment to a friend and social self-efficacy. It can also be inferred that the children whose parents are authoritative can develop a secure attachment style which lead to social self-efficacy. The children of the authoritarian and protective parents, on the other hand, can develop anxiety-avoidant style which leads to having difficulty in making friends, and having a lower social self-efficacy.

People's self-efficacy is related to their specific problem-solving experiences (Bandura, 1986; Caprara et al. 2003). People learn how to solve the problems through their observation and imitation of people around them. Bandura (1986) claims that the perception of self-efficacy influences problem-solving skills. Additionally, Matsushima and Shiomi (2003) have revealed that people with high self-efficacy spend more efforts to struggle with problems since they believe in themselves about their capacity and their perception to solve the problems.

In addition, Bandura (2000), claims that people with higher self-efficacy have more cognitive skills and they are more initiative in their strategic flexibility and in controlling their environment. However, people with low self-efficacy avoid challenging tasks since they perceive these difficulties as threats. It is claimed that these people exhibit low willingness and they are against taking responsibilities (Matsushima, and Shiomi, 2003).

According to Rosenbaum (1980), "learned resourcefulness" is a behavioral and cognitive skills repertoire used to control internal responses. The fundamental factor affecting the appearance and development of learned resourcefulness is that one repeatedly show accomplishments. Thus, learned resourcefulness is related with enactive mastery experience, one of the sources of self-efficacy. Enactive mastery experiences provide the most authentic evidence on whether one can master whatever it takes to succeed. Successes build a robust belief in one's personal efficacy (Bandura, 1997). In other words, self-efficacy comes out of previous experiences, based on similar events and can be generalized into situations requiring different skills (Bandura 1997). Bandura (1997) defines this as the generality which is one of the dimensions of self-efficacy. Generality makes self-efficacy acquired in one situation to be used in another (Bandura, 1997). Thus, learned resourcefulness might be a trait acquired as an outcome of mastery experiences processes of self-efficacy. The person can solve the problems through enactive mastery experiences, generalise it, and they finally can raise learned resourcefulness. In addition, Rosenbaum (1980), Rosenbaum and Ben-Ari (1985), and Lewinsohn, and Alexander (1990) have concerned positive relationship between the learned resourcefulness and one's perception of self-efficacy. According to Rosenbaum (1983), in order to be effective in dealing with stress it is essential that the inner events be controlled.

Controlling inner events is in direct proportion with development of the self-control skills, which is a symbol of self-efficacy (Baumrind, 1991; Karavalis et al., 2003; Lamborn et al., 1991).

The Structural Equation Model

The model to be used in this research has based on three hypotheses; (a) effective self-efficacy used in relationships with others is gained through successful interpersonal relationships, (b) the capacity to share positive and negative feelings is gained through positive relationships with others (Caprara et al., 2003), (c) self-efficacy leads one to gain problem-solving skills (Bandura, 1986). As illustrated in Figure 1, social self-efficacy is influenced by parental attitudes (Bandura, 1986). According to Karavalis et al (2003) one may develop social self-efficacy depending on his parental attitudes. In addition, the adolescent’s relationships with his family and friends make him feel more social self-efficant. He can then improve his problem-solving skills through experiences in his social relationships (Caprara et al., 2003). Thus, according to the model to be investigated in this study (Figure 1), perceived parents’ attitudes effect the adolescent’s attachment to his parents and peers, and then peer and parents attachment result in social self-efficacy. Finally, social self-efficacy effects problem-solving and learned resourcefulness skills (Figure 1). In addition, problem-solving skill brings about learned resourcefulness. Although language and reasoning underlying the hypotheses and the results are causal, the analyses cannot demonstrate causality, given the cross-sectional nature of the study.

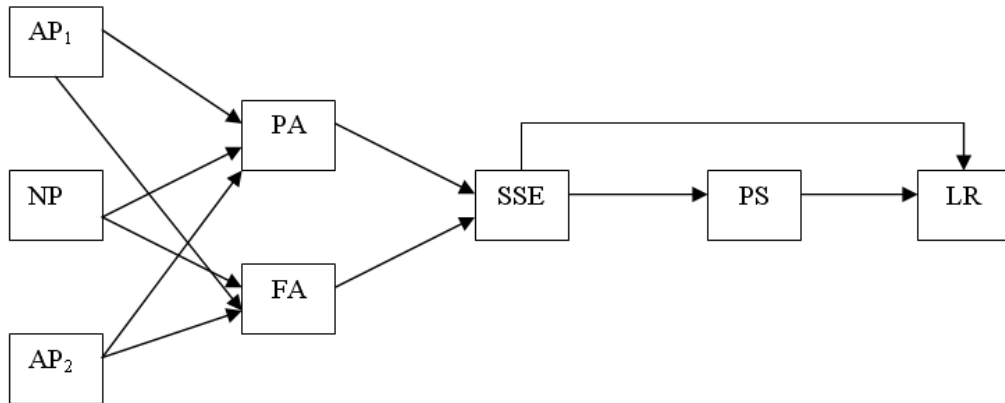

Figure 1. Hypothetical relations among the variables. Actual relations among the variables with the full sample (N=255). AP₁: Authoritative Parenting; AP₂: Authoritarian Parenting; NP: Negligent Parenting; FA: Peer Attachment; PA: Parenting Attachment; SSE: Social Self-efficacy; PS: Problem-Solving; LR: Learned Resourcefulness.

METHOD

Participants

During 2004–2005 academic year, 255 students 123 female (48.2%) and 132 male (51.8%) first year and sophomore students of a university, located in the southern part of Turkey. The ages of the students ranged between 17 and 20; 42 (16.4%) were 17 years old, 83 (32.6%) were 18, 69 (%27.1) were 19 and 61 (23.9%) were 20 years old.

Procedure

The participants were informed about the study in the beginning of the data collection process. They were told that their mid-term exams would be graded on a higher degree, so the inventories used in this study were administered by the researcher during their class hours –in three different class hours during three weeks. When needs arouse, participants were instructed by the researcher. The participants were exoected to respond to the questions in the inventories in 50 minutes each week. In addition, they were told that they could get the results of the inventories if they wished.

Instruments

The Inventory of Parents' Attitudes (IPAT): The inventory –developed by Kuzgun and Eldelekoğlu (2005)- is designed to determine actual parents' attitudes. Parent attitudes are perceived. The inventory consists of three sub-scales: authoritative, authoritatian and negligent parenting (For example: authoritative sub-scale item:“At home, my parents encourage me to point what I think while discussing atopic”, authoritatian sub-scale item: “Considering not positive sides of what I do but failures my parents criticise me”, and negligent suc-scale item: “They are always worry where I be and what I do” The inventory consists of 40 items and 1-5 Likert rating scale. High marks taken from each sub-scale has indicated the presence of that parents' attitude (Kuzgun, and Bacanlı, 2005).

In order for the validity factor analysis was administered. The factor loads of the inventory changed from .31 to .69. As for the reliability, Cronbach Alpha reliability coefficient was found to be .89 for authoritative parenting sub-scale, .78 for authoritatian parenting sub-scale, and .82 for negligent parenting sub-scale. The stability coefficient, based on the test-retest method, was found to be .92 for authoritative parenting sub-scale, .75 for negligent parenting sub-scale, and .79 for authoritatian parenting sub-scale (Kuzgun, and Bacanlı, 2005).

The Inventory of Peer Attachment (IPEA): The inventory of peer attachment –developed by Armsden and Greenberg (1987)- is designed to measure the dimensions of cognitive-affective attachment between adolescents and their friends. It was adapted into Turkish by Hortaçsu and Oral (1991).

It consists of 25 items and 1-5 Likert rating scale. (For example; “I ask for advice of my friends when I feel anxious”). To exemplify; the original form of the inventory, there respect, understanding and trust sub-dimensions. However, only total marks were used because factor analysis were consistent with the original form during the adaptation process (Löker, 1999). The high marks taken from the inventory increased peer attachment.

Löker (1999) determined the Cronbach Alpha coefficient as .92 in the reliability studies of the inventory. The correlation of items was found to be between .51 and .75. In addition, Akkapulu (2005) found the internal consistency coefficient as .91, half-split test as .95 and test-retest coefficient as .71.

Convergent validity studies by Akkapulu's (2005) revealed the correlation coefficient between IPEA and ISSE-A (Inventory of Social Self-Efficacy-Adolescent Form) as .44, IPEA and OSIQ (Offer Self-Image Questionare) as .25, and IPEA and IPAA (Inventory of Parent Attachment) to be .25.

The inventory of parent attachment (IPAA): The inventory of parent attachment –developed by Armsden and Greenberg (1987) and adapted into Turkish by Hortaçsu, and Oral (1991)- was used to measure the cognitive and affective dimensions of parent attachment.

It consists of 28 items and 1-5 Likert rating scale. (For example; my parents respect my feelings and opinions”). Total scores used for the inventory and the high marks taken from the inventory revealed strong attachment.

The Cronbach Alpha coefficient of the inventory found by Löker (1999) is .92. In addition, the correlation of the items was found to be ranging between .11 and .59. The result of the factor analysis indicated a structure with three-factors. Akkapulu (2005) found the inner consistency coefficient .68, half-test coefficient .66 and reliability coefficient based on the test-retest method .71. Item-total item score coefficient was between .36 and .72.

Furthermore, the result of Akkapulu’s convergent validity studies (2005), indicated that the correlation coefficient between IPAA and OSIQ (Offer Self-Image Questionnaire) was .35. Akkapulu (2005) also discovered that regarding convergent validity, the correlation between IPAA and SSES-A was .40, and the correlation between IPAA and IPEA was .25.

The Inventory of Social Self-efficacy-Adolescent Form (ISSEA): Inventory of Social Self Efficacy-Adolescent Form –developed by Bilgin (1999)- was used to measure adolescents’ social self-efficacy levels. Inventory of Social Self-efficacy-Adolescent Form was based upon strength dimension of self-efficacy. The inventory having a five-point Likert scale consisted of 40 items (For example: “I can help my friends during the preparation of their homework”, “I can be volunteer in the organisation of a schools party” “I can tell my friend that I congratulate him/her for his/her success” .“I can tell my feelings to a friend who has offended me”, “I can join a birthday party held by one of the popular friends in my class”). Participants having the the high scores were considered as those having high social self-efficacy.

Factor analysis was conducted for the structural validity of the inventory. The result of the factor analysis indicated that the factor loads were ranging from .31 and .70, based on five factors (Bilgin, 1999). These factors are the dimensions of assertiveness, eagerness in common relations, joining a social group or activity, being sincere and friendly, and receive and give help. The convergent validity studies by Akkapulu (2005), gives evidence that proven that the correlation between the OIIS (Offer Identity Image Scale) and SSES-A is .51, the correlation between SSES-A and the IPAA (Inventory of Parent Attachment) is .40, and the correlation between SSES-A and the IPEA (Inventory of Peer Attachment is) .44.

The reliability coefficient based on half-split test method was found to be.86. The Cronbach value of internal consistency coefficient was .93 for the whole inventory. Item-total score correlation of the inventory was between .43 and .56 (Bilgin, 1999). In the study carried out by Akkapulu (2005) the internal consistency co-efficient is .82; the correlation, based on split half method, .90; and the reliability coefficient, based on test-retest method, .69.

The Problem-Solving Inventory (PSI): The inventory developed by Heppner and Petersen (1982) and adapted into Turkish by Şahin, Şahin and Heppner (1993) aims to evaluate people’s self-confidence and individual control emotions and their approach styles (Savaşır, and Şahin, 1997).

The inventory consists of a six-point Likert scale (For example; I don’t analyze why I am unsuccessful when my solutions fail”). The high marks taken from the inventory represented the respondent’s inadequate self-perception about problem-solving skills and low marks represented high skill of problem-solving skills (Savaşır, and Şahin, 1997).

As for the values during the adaptation process, the Cronbach Alpha reliability value was .88. The reliability coefficient, based on split-half method was .81. In convergent validity studies, the correlation between Beck Depression Inventory and PSI was .33 and the correlation between Situational-Continuos Anxiety Inventory and PSI was .45. The factor analysis indicated that the internal consistency coefficient was ranging from .59 and .78, based on 6 factors (Savaşır, and Şahin, 1997). This factors are general orientation, problem definition, generation of alternatives, decision making, and evaluation.

Rosenbaum's Learned Resourcefulness Inventory (RLSI): The inventory developed by Rosenbaum (1980) was designed to see to what extent a person can make use of his cognitive strategies when facing stressful situations and to measure self-control skills. It consists of 36 items and has a five-scale Likert scale (For example; "when I come across a difficult problem, I regularly look for solutions"). The highest scores represent the productive use of self-control skills (Savaşır, and Şahin, 1997).

Rosenbaum's Learned Resourcefulness Inventory was adapted into Turkish by Siva (1991). The Cronbach Alpha reliability value was .78. For the test-retest reliability was found to be .80. Rotter Internal-external control focus inventory was used for validity, and the correlation was found to be -.40 (Savaşır, and Şahin, 1997).

The structural validity of Rosenbaum's Learned Resourcefulness Inventory revealed the 12 factors forming the % 58.2 of total variance. These factors were being fussy, controlled psychological mood, controlled undisered thoughts, controlled driven, having a plan, being self-confident and being calmed, cotrolling pain, postponement, seeking help, being optimist, concentration, flexible planning and looking for supervising (Savaşır, and Şahin, 1997).

RESULTS

Relationship Among Variables

Descriptive data on all of the variables and the bivariate relations among the variables appear in Table 1. As seen, except for authoritarian parenting there exists meaningful relationships between social self-efficacy and other variables. The highest correlation between social self-efficacy and peer attachment is ($r=.56, p<.05$). Similarly, meaningful relationships can be observed between social self-efficacy and parent attachment/problem-solving skills. In the lights of the results, Figure 1 illustrates the paths between social self-efficacy and peer attachment/parent attachment, problem-solving skills. There is a negative correlation between problem-solving skills and other variables. Since the lower the scores obtained from problem-solving inventory get the higher problem-solving skill is, yet, the increase in other inventories symbolize the increase of that quality. The negative correlation between authoritarian parenting and other variables –except for problem-solving skills- was regarded as a significant point.

Table 1. Descriptive Statistics and Bivariate Relations Among The Attachment, Parent Attitudes, Social Self-Efficacy, Problem-Solving Skills and Learned Resourcefulness

	1	2	3	4	5	6	M	SD
1 LR	-						123.98	16.58
2 PS	-.52*	-					85.14	19.02
3 SSE	.2*	-.37*	-				140.42	19.23
4 FA	.22*	-.39*	.56*	-			99.52	13.26
5 PA	.29*	-.40*	.31*	.37*	-		102.22	16.27
6AP1	.33*	-.30*	.30*	.30*	.66*	-	34.94	11.11
7 AP2	-1.8*	.20*	-1.0	-.21*	-.59-	-.68*	39.77	6.75

LR: Learned Resourcefulness Scale; PS: Problem-Solving; SSE: Social self-efficacy; FA: Peer Attachment; PA: Parenting Attachment; AP₁: Authoritative Parenting; AP₂: Authoritarian Parenting.

*p<.05.

Determination of Model Fit

To assess the goodness of fit of the model tested in this study, χ^2 value and fit indices were used. Since χ^2 value was found to be meaningful when large samples were referred, other fit indices were also used. In addition, goodness of fit index (GFI), incremental fit index (IFI), comparative fit index (CFI), standardized root mean square residual (standardized RMR), and root mean square error of approximation (RMSEA) were administered, but rival model was not specified. Therefore, consistent Akaike's information criterion (CAIC) was used. When the CAIC value of the hypothesized model was lower than either independence or saturated model, it was thought that they were adjusted into the database of the hypothesized model since rather than rival they were planned models. In addition, for the issue of parsimony in the assessment of model fit, statistical goodness-of-fit, as well as sample size and number of estimated parameters, was taken into account. In the independence model, all correlations among variables were zero. The saturated model was also called as a "full" model. The goodness of fit of the model to the database was determined if GFI, IFI, and CFI values were .90 and above and if standardized RMR and RMSEA were below .10 (Detailed discussions of the model fit indexes and criteria is available in Bollen, 1989; Byrne, 1998; Hoyle, and Panter, 1995; Hu, and Bentler, 1995; Kline, 1998).

Results of The Model

LISREL 8.30 (Jöreskog, and Sörbom, 1993) with maximum-likelihood estimation was used to examine relations in Figure 1. As seen, the analysis was administered by making use of the observed variables. Model specification carried out for testing the model is in the Figure 1 as well. In the first analysis, the NP (negligent parenting) observed variable was not noteworthy to predict FA (peer attachment) and PA (parenting attachment), hence they were excluded from NP (negligent parenting) model. PA (parent attachment) was also not predictable for the SSE (social self-efficacy), and AP₂ (authoritarian parenting) was not for the FA (peer attachment). Thus, these links were fixed and the model was modified.

In the second analysis, all links were significant and GFI, IF, and CFI values were above .90. However, values of RMSEA and standardized RMR were not below .10. In the lights of these findings, modification indices were analyzed and it was seen that the highest modification index was between PA (parent attachment) and PS (problem-solving). In addition, the link from PA (parent attachment) to PS (problem-solving) was provided.

In the third analysis (see Figure 2), GFI, IFI, CFI, RMSEA and standardized RMR values were satisfactory (see Table 2). In addition, the output analysis of models regarding CAIC values revealed that this last hypothesis model represented the best fit for the data (CAIC values: for the test modified model 169.37, for independence 431.88 and for saturated 169.22). However, it requires attention that the value of saturated model has been a bit higher. Table 2 displays the indirect effects of the modified model. A covariance matrix related to the model can be sent to interested researchers on request.

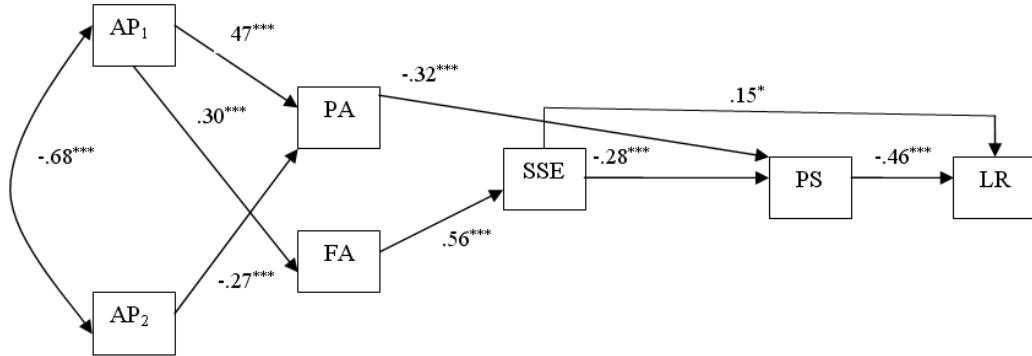

Figure 2. The model modified in the study. AP₁: Authoritative Parenting; AP₂: Authoritarian Parenting; FA: Peer Attachment; PA: Parenting Attachment; SSE: Social Self-efficacy; PS: Problem-Solving; LR: Learned Resourcefulness. For LR $R^2=.28$; For PS $R^2=.20$; For SSE $R^2=.31$; For PA $R^2=.09$; and FA $R^2=.47$. All values standardized values. * $p<.05$, *** $p<.001$

Table 2. Fit indices for the model

	χ^2	<i>df</i>	<i>GFI</i>	<i>IFI</i>	<i>CFI</i>	<i>RMSEA</i>	<i>SRMR</i>
Model	31.24**	12	.95	.95	.95	.10	.08

** $p < .01$

Alternative Models

Although the refined model provided fit for the empirical data, plausible alternative models were also tested. One structural model gave causal primacy to, problem-solving skills, effecting the various forms of social self-efficacy, which in turn effect learned resourcefulness. This model provided a poorer fit to the data. It yielded a significant chi square .30.18 ($df=12$), $p<.01$, and fared less well on the other indices of goodness of fit, with a $CFI=.92$, and an $RMSEA=.041$.

A second plausible model reversed the direction of causation, with learned resourcefulness influencing problem-solving skills, which in turn influences the different forms of social self-efficacy. Even this model provided a poorer fit for the data. It yielded a significant chi square .32.2 ($df=12$), $p<.01$, and fared less well on the other indices of goodness of fit, with a $CFI=.90$, and an $RMSEA=.046$.

DISCUSSION

With the words of Pedhazur and Pedhazue-Schmelkin (1991) structural equation model is a study subject in which no causation without manipulation is discussed. Thus, the causation

model stated in this study is consistent with the theory and far more meaningful than theoretical causation (Tuijman and Keeves, 1997; Hair, Tahtam, Anderson, and Black, 1998).

In this study, the relationships between perceived parental attitudes, parent and peer attachment, social self-efficacy, problem-solving skills, and learned resourcefulness were investigated. Thus, a structural equation model was used. The results revealed that authoritative parenting and peer attachment effect social self-efficacy. As a result, the late adolescents acquire social self-efficacy resulting in learned resourcefulness.

According to Bandura (1986), Corcoran and Mallinckroth (2000), Coleman (2003), Field et al (2002), and Karavalis et al (2003) have stated that due to parental attachment, parental attitudes has an effect on social self-efficacy. In addition, authoritative parenting is more effective on social self-efficacy through reliable parent attachment which in turn enables the adolescents to feel more self-efficant (Karavalis et al., 2003; Lamborn et al., 1991). This study pointed out that there is a meaningful relationship between authoritative parenting and parental and peer attachment. Although, in this study, a link between parental attachment and social self-efficacy was not observed. But a link between parental attachment and problem-solving skills was observed. Furthermore, in this study, there is a meaningful negative relationship between authoritative parenting and parental attachment but there is not a meaningful relationship between authoritative parenting and peer attachment. The results of this also indicated that due to parent attachment, authoritative and authoritative parenting did not have an effect on social self-efficacy, but have a direct effect on problem-solving skills and thereby learned resourcefulness.

Authoritative parenting can help the adolescents solve their problems on their own and encourage them (Baumrind, 1971, 1991; Lamborn et al., 1991; MacCoby, and Martin, 1983; Steinberg et al., 1992; Steinberg et al., 1995). Karavalis et al (2003) showed that authoritative parenting supporting parental attachment may encourage the child to develop his skills which enable the child to get to know oneself more rapidly and to feel independent. Furthermore Bowlby (1969) and Bretherton (1985) have studied the connection between attachment and problem-solving skills.

In this study, a link between authoritative parenting and peer attachment was observed. In addition, a link between peer attachment and social self-efficacy was observed. As related studies have revealed, authoritative parenting facilitates adjustment and relationship with friends (MacCoby, and Martin, 1983; Parish, and McCluskey, 1992), Adolescents receiving authoritative parenting, on the other hand, are more initiative and active in interpersonal relationships (Karavalis et al., 2003). Furthermore, studies have pointed out that adolescents receiving authoritative parenting are more volunteered in starting relationships with their friends (Bartholomew, and Harowitz, 1991; Crittenden, 1992; Hazan, and Shaver, 1994). Dekovic and Meeus (1997) pointed out that authoritative parenting has a facilitative role in interpersonal relationships. As pointed out by Lempers and Clark-Lempers (1992) peer attachment is significantly correlated with social relationship. In addition Coleman (2003) has found out meaningful relationships between peer attachment and social competence. Bandura (2000) has suggested that social self-efficacy can play a great role in acquiring problem-solving skills. Self-efficacy can also provide the acquisition of learned resourcefulness (Karavalis et al., 2003).

On the other hand, although authoritative parenting can be effective in relations with peer attachment, there did not seem to be any relationships between authoritative parenting and peer attachment. Less behavior problems in authoritarian parenting (Steinberg et al., 1995)

implies that the adolescents are socially distant to friends in the relationships, so they can not establish deep relationships, and they often changes their friends. Such cases may reveal that the adolescents do not have close relationships with their friends and they do not care who their friends are. The benefits of positive parenting (being responsive, supportive and loving) concerning their children's social competence in interactions with peers have been in the agenda of Putallaz (1987). According to Melby, Conger, Conger and Lorenz, (1993), however, parental strictness and a lack of flexibility in rearing practice are related to deviant behavior and a disorted development of social skills of adolescents. Authoritarian parenting have negative influences on adaptation (Isabella, 1993; Lamborn et al., 1991; Stevenson-Hinde, and Shouldice, 1995; Steinberg et al., 1995). A positive relationship between authoritarian parenting and solicitous/avoidance attachment (Karavalis et al., 2003; Strayer, and Preece, 1999). Solicitous attachment negatively effects interpersonal relationships. Children whose parents are using passive problem-solving skills have solicitous attachment style (Greenberger, and McLaughlin, 1998; Harvey, and Byrd, 2000).

Figure 2 shows that there is no path between parental attachment and social self-efficacy conflicting with the model tested in this study hypothesizing that there would be a link between parental attachment and social self-efficacy. However, studies have revealed that there is a close relationship between parental attachment and social self-efficacy (Corcoran, and Mallinckroth, 2000). It is assumed that it may have resulted from cultural factors since relationships with parents are concerned more importantly than those with friends by both parents and adolescents in Turkish society (Bilgin, 2001). Turkish adolescents might perceive parental attachment as dependence which led to the conclusion that there is no relation between social self-efficacy and parental attachment. However, studies have reported the relation between social self-efficacy independent behavior supported by parental attachment (Bandura, 1986; Karavalis et al., 2003).

Another hypothesis tested in the study is that social self-efficacy can brought about learned resourcefulness due to problem-solving skills. The findings of the study prove this hypothesis since there seems to be a path between social self-efficacy and problem-solving skills. In addition, it was hypothesized that both variables would account for the learned resourcefulness. The result of the present study, revealed a link between problem-solving skills and social self-efficacy. Although it was not hypothesised that there would not be a link between social self-efficacy and learned resourcefulness, a direct link between social self-efficacy and learned resourcefulness was found. Social self-efficacy shows an direct link due to learned resourcefulness, and it is also effective on the learned resourcefulness on account of problem-solving skills. Bandura (1995) has stated that social self-efficacy effects problem-solving skills. In addition, Caprara et al (2003) have pointed out a positive relationship between problem-solving skills and social competence. In addition problem-solving skill and learned resourcefulness were found to be a predictor of social self-efficacy (Bilgin, and Akkapulu, 2007). The link observed in this study between social self-efficacy and problem-solving skills show consistency with the related studies. Rosenbaum (1980) and Lewinson, and Alexander (1990) have emphasized a positive relationship between the learned resourcefulness and social self-efficacy. Furthermore, Rosenbaum (1983) has stated that the only way to deal with stress is to control inner feelings. Similarly, Karavalis (2003) has stated that taking the inner flow of feelings under control is directly related with developing one's self-control skills. Thus, we can state that social self-efficacy is gained through the experience in interpersonal relationships, and then it becomes a behavior chain and is recorded into the behavioral repertoire. We can also state that social self-efficacy experiences may change into the learned resourcefulness; hence, in this study, a link between social self-efficacy and the learned resourcefulness was observed.

As for the implications and suggestion of the study, First of all, parent attachment was not measured through different dimensions. However, social self-efficacy relationships with particular reference to reliable and solicitous/avoidance attachment could be analysed. Secondly, since the aim was to analyse attachment regarding social self-efficacy, the focus on attachment was not in different dimensions. It is advised that follow up studies focusing on different dimensions be carried out. The next is that the study was carried out with late adolescents, so a parallel study on adolescents and adolescents should be conducted, and all results regarding social self-efficacy from different adolescence phases can be compared. For the follow-up studies, peer attachment and social self-efficacy should be studied in details since a meaningful relationship but no link was observed between these two variables.

To conclude, perceived parenting style, peer attachment and parent attachment are effective on social self-efficacy. Social self-efficacy influences problem-solving skills and learned resourcefulness skills. In addition, among all parent attitudes, authoritative parenting is not only influential on peer attachment but also parental attachment. Authoritarian parenting is, to some extent, influential on parental attachment but preventive attitudes effect neither peer attachment nor parent attachment. The high influence of authoritative parenting on peer and parent attachment leads the adolescents to be more volunteered and encouraged in starting social relationships, which enable the adolescents to develop their problem solving skills. Moreover, positive experience gained through interpersonal relationships is recorded as a learned resourcefulness skill for the future use.

REFERENCE

- Akkapulu, E. (2005). *Some variables which predict the social self-efficacy*. (Unpublished Master Thesis), Social Science Institute, Çukurova University. Adana
- Arbano, C., & Power, T. (2003). Parental attachment, self-esteem and antisocial behaviors among African American, European American, & Mexican American adolescents. *Journal of Counseling Psychology*, 40-51.
- Armsden, G., & Greenberg, M. (1987). The inventory of parent and peer attachment: Individual differences and their relationship to psychological well-being in adolescence. *Journal of Youth and Adolescence*. 16, 427-454.
- Bandura, A. (1977). Self-efficacy: Toward a unifying theory of behavioral change. *Psychological Review*, 84, 191-215.
- Bandura, A. (1986). *Social Foundations of Thought and Action: A Social Cognitive Theory*. Englewood Cliffs, New Jersey: Prentice-Hall Inc. 415-416.
- Bandura, A. (1995). *Self-efficacy in Changing Societies*. Cambridge: Cambridge University Press. 138-139.
- Bandura, A., Barbaranelli, C., Caprara, G.V., & Pastorelli, C. (1996). Multifaceted impact of self-efficacy beliefs on academic functioning. *Child Development*, 67, 1206-1222.
- Bandura, A. (1997). *Self-efficacy: The exercise of control*. New York: W.H. Freeman and Company.

Bandura, A. (2000). *Self-efficacy*. In A.C.E. Kazdin (Ed.), *Encyclopedia of psychology Vol 7* New York: Oxford University Press, pp. 212-213.

Bandura, A., Barbaranelli, C., Caprara, G.V., & Pastorelli, C. (2001). Self-efficacy beliefs as shapers of children's aspirations and career trajectories. *Child Development*, 72, 187-206.

Bandura, A., Pastorelli, C., Barbaranelli, C., & Caprara, G.V. (1999). Self-efficacy pathways to childhood depression. *Journal of Personality and Social Psychology*, 76, 258-269.

Bartholomew, K., & Horowitz, L.M. (1991). Attachment styles among young adults: A test of a fourcategory model. *Journal of Personality & Social Psychology*, 61, 226-244.

Baumrind, D. (1971). Current patterns of parental authority. *Developmental Psychology*, 4, 1-103

Baumrind, D. (1991). *Effective parenting during the early adolescent transition*. In P. Cowan & E.M. Hetherington (Ed.), *Family Transitions: Advances in family research series* (pp. 111-163). Hillsdale, NJ: Lawrence Erlbaum Associates Inc.

Bilgin, M. (2001). Investigate the effect of university student's values on their dysfunctional attitudes in term of some variables. *Journal of Social Sciences*, 8, 8, 33-53.

Bilgin, M. (1996). *A Experimental studies of effect of group guidance on social self-efficacy expectation of students*. (Unpublished Doctoral Thesis), Social Science Institute, Çukurova University, Adana.

Bilgin, M. (1999). Developing a social self-efficacy expectation scale for adolescents at the age of 14-18. *Turkish Psychological Counseling and Guidance Journal*. 2, 12, 7-15.

Bilgin, M., & Akkapulu, E. (2007). Some variables predicting social self-efficacy expectation. *Social Behavior and Personality*. 35,6, 777-788.

Bollen, K.A. (1989). *Structural equations with latent variables*. New York: John Wiley.

Bowlby, J. (1969). Disruption of affectional bonds and its effects on behavior. *Canada's Mental Health Supplement*, 59, 12.

Bretherton, I. (1985). Attachment theory: Retrospect and prospect. *Monographs of the Society for Research in Child Development*, 50, 3-35.

Bretherton, I., Golby., & Cho, E. (1997). *Attachment and the transmission of values*. In J.E. Grusec & L., Kuczyski (Ed.), *Parenting and children's internalization of values* (pp. 103-134). New York: Wiley.

Byrne, B. M. (1998). *Structural equation modeling with LISREL, PRELIS, and SIMPLIS: Basic concepts, applications, and programming*. Hillsdale, NJ: Lawrence Erlbaum Associates Inc.

- Caprara, G. V., & Steca, P. (2005). Self-efficacy beliefs as determinants of prosocial behavior conducive to life satisfaction across ages. *Journal of Social and Clinical Psychology*, 24,2,191-217.
- Caprara, G. V., Steca, P., Cervone, D., & Artisticco, D. (2003). The contribution of self-efficacy beliefs to dispositional shyness: On social-cognitive systems and the development of personality dispositions. *Journal of Personality*, 71, 6, 943-970.
- Caprara, G.V., Regalia, C., & Bandura, A. (2002). Longitudinal impact of perceived self-regulatory efficacy on violent conduct. *European Psychologist*, 7, 63-69.
- Crittenden, P.M. (1992). Quality of attachment in the preschool years. *Development and Psychopathology*, 4, 209-241.
- Coleman, P. K. (2003). Perceptions of parent-child attachment, social self-efficacy and peer relationship in middle childhood. *Infant and Child Development*. 12, 352-368.
- Corcoran, K. O., & Mallinckrodt, B. (2000). Adult attachment, self-efficacy, perspective taking, and conflict resolution. *Journal of Counseling & Development*, 78, 4, 473-484.
- Connolly, J. (1989). Social self-efficacy in adolescence; Relations with self-concept, social adjustment, and mental health. *Canadian Journal of Behaviour Science Review*, 21, 3, 258-269.
- Dekovic, M., & Meeus, W. (1997). Peer relations in adolescents: Effects of parenting and adolescents' self-concept. *Journal of Adolescence*, 20, 163-176.
- De Wolff, J., & IJzendoorn, M. H. (1997). Sensitivity and attachment: A meta-analysis on parental antecedents of infant attachment. *Child Development*, 68, 571-591.
- Feeney, J. A., & Noller, P. (1990). Attachment style as a predictor of adult romantic relationships. *Journal of Personality and Social Psychology*, 58, 281-291.
- Field, T., Diego, M., & Sanders, C. (2002). Adolescents' parent and peer relationships. *Adolescence*, 37, 145, 121-131.
- Greenberger, E., & McLaughlin, P. (1998). Attachment, coping, and explanatory style in late adolescence. *Journal of Youth and Adolescence*, 27, 121-139.
- Gresham, F. M. (1984). Social skills and self-efficacy for exceptional children. *Exceptional Children*. 51, 3, 253-261.
- Gianino, A., & Tronick, E. Z. (1988). *The mutual recognition model: The infant's self and interactive regulation coping and defense capacities*. In T. Field, P. McCabe, & N. Schneiderman (Ed.), *Stress and coping* (pp. 47-68). Hillsdale, NJ: Erlbaum.
- Hair, J.F., Tatham, R.L., Anderson, R.E., & Black, W. (1998). *Multivariate data analysis*. New York: Prentice Hall.

- Harvey, M., & Byrd, M. (2000). Relationships between adolescents' attachment styles and family functioning. *Adolescence*, 35, 138, 345-357.
- Hazan, C., & Shaver, P. (1987). Romantic love conceptualized as an attachment process. *Journal of Personality and Social Psychology*, 52, 511-524.
- Hazan, C., & Shaver, P. (1994). Attachment as an organizational framework for research on close relationships. *Psychological Inquiry*, 5, 1-22.
- Hortaçsu, N., & Oral, A. (1991). Factors affecting relationships of Turkish adolescents with parents and same-sex friends. *Journal of Social Psychology*, 131, 3, 413-427.
- Howard, M., & Medway, F. (2004). Adolescents' attachment and coping with stress. *Psychology in the School*, 41, 3, 391-403.
- Hoyle, R. H., & Panter, A. T. (1995). *Writing about structural equation models*. In R. H. Hoyle (Ed.), *Structural equation modeling: Concepts, issues, and application* (pp. 76-100). London: Sage.
- Hu, L., & Bentler, P. M. (1995). *Evaluating model fit*. In R. H. Hoyle (Ed.), *Structural equation modeling: Concepts, issues, and application* (pp. 76-100). London: Sage.
- Isabella, R. A. (1993). Origins of attachment: Maternal interactive behavior across the first year. *Child Development*, 64, 605-621.
- Jöreskog, K. G., & Sörbom, D. (1993). *LISREL 8: Structural equation modeling with the SIMPLIS command language*. Chicago, IL: Scientific Software International.
- Karavalis, L., Doyle, A. B., & Markiewicz, D. (2003). Associations between parenting style and attachment to mother in middle childhood and adolescence. *International Journal of Behavioral Development*, 27, 2, 153-164.
- Kline, R. B. (1998). *Principles and practice of structural equation modeling*. New York: Guilford Press.
- Kobak, R. R., & Sceery, A. (1988). Attachment in late adolescence: Working models, affect regulation, and representation of self and others. *Child Development*, 59, 135-146.
- Kuzgun, Y., & Bacanlı, F. (2005). *Used to scale in counseling*. Ankara: Nodel Publication
- Lamborn, S. D., Mounts, N. S., Steinberg, L., & Dornbusch, S. M. (1991). Patterns of competence and adjustment among adolescents from authoritative, authoritarian, indulgent, and neglectful families. *Child Development*, 62, 1049-1065.
- Lempers, J. D., & Clark-Lempers, D. S. (1992). Young, middle, and late adolescents' comparisons of the functional importance of five significant relationships. *Journal of Youth and Adolescence*, 21, 54-96.
- Lewinsohn, P. M., & Alexander, C. (1990). *Learned resourcefulness and depression*. In M. Rosenbaum (Ed.), *Learned resourcefulness*. (pp. 202-217). New York: Springer Publishing Company.

Lieberman, M., Doyle, A.B., & Markiewicz, D. (1999). Developmental patterns in security of attachment to mother and father in late childhood and early adolescence. Associations with peer relations. *Child Development*, 70, 202-213.

Löker, Ö. (1999). Differential effects of parent and peer attachment on social and emotional loneliness among adolescents. (Unpublished Master Thesis), Social Science Institute, Middle East Technical University. Ankara.

Maccoby, E. E., & Martin, J. A. (1983). *Socialization in the context of the family parent-child interaction*. In E.M. Hetherington (Ed.), and P. H. Mussen (series Ed.), *Handbook of child psychology: Volume 4. Socialization, personality, and social development* (pp. 1-101). New York: Wiley.

Malinckrodt, B. (1992). Childhood emotional bonds with parents, development of adult social competencies, and the availability of social support. *Journal of Counseling Psychology*, 39, 453-461.

Matsushima, R., & Shiomi, K. (2003). Social self-efficacy and interpersonal stress in adolescence. *Social Behavior and Personality an International Journal*. 31, 4, 323-332.

MacDonald, P. M. (1998). Mother-child interactions and relations in adolescence: Modes of linkage. *Dissertation Abstracts International*, 59, 3095.,

Melby J.N., Conger, R.D., Conger, J.K., & Lorenz, F.O. (1993). Effects of parental behavior on tobacco use by young male adolescents. *Journal of Marriage and The Family*, 55, 439-454.

Parish, T., & McCluskey, J. (1992). The relationship between parenting styles and young adults' self-concept and evaluations of parents. *Adolescence*, 27, 915-918.

Pedhazur, E.J., & Pedhazur-Schmelkin, L. (1991). *Measurement, design, and analysis: An integrated approach*. New Jersey: Lawrence Erlbaum.

Putallaz, M. (1987). Maternal behavior and children's sociometric status. *Child Development*, 58, 324-340.

Rice, K.G. (1990). Attachment in adolescence: A narrative and meta-analytic review. *Journal of Youth and Adolescence*, 19, 511-538.

Rice, K.G., Cunningham, T.J., & Young, M.B. (1997). Attachment to parents, social competence, and emotional well-being: A comparison of Black and White late adolescents. *Journal of Counseling Psychology*, 44, 89-101.

Rosenbaum, M. (1980). Individual differences in self-control behaviors and tolerance of painful stimulation. *Journal of Abnormal Psychology*. 89, 581-590.

Rosenbaum, M. (1983). *Learned resourcefulness as a behavioral repertoire for the self-regulation of internal events: Issues and speculations*. (Ed:Franks, C. M. & Y. Jaffe), *Perspectives on Behavior Therapy in the Eighties*. New York: Springer.

Rosenbaum, M., & Ben-Ari, K.(1985). Learned helplessness and learned resourcefulness: Effects of noncontingent success and failure on individuals differing in self-control skills. *Journal of Personality and Social Psychology*. 48, 1, 198-215.

Savaşır, İ., & Şahin, N. H. (1997). *Assesment to cognitive behavioral therapy*. Ankara: Turkish Psychological Association Publishing, 9. 79-100.

Siva, A. (1991). Investigation to cope with stress, and strength, and depression ininfertilitte. (Unpublished Master Thesis), Nerology and Psychiatry Science Instute, Hacettepe University. Ankara.

Steinberg, L. (1998). *Adolescence*. New York: McGraw-Hill College Companies.

Steinberg, L., Darling, N., Fletcher, A., Brown, B., & Dornbusch, M. (1995). *Authoritative parenting and adolescent adjustment: An ecological journey*. In P. Moen, G. H. Elder, Jr, & K. Luscher (Ed.), *Examining lives in context: Persrepectives on the ecology of human development* (pp. 423-466). Washington, DC: APA.

Steinberg, L., Lamborn, L. D., Dornbusch, S. M., & Darling, N. (1992). Impact of parenting practices on adolescent achievement: Authoritative parenting, school involvement, and encouragement to succeed. *Child Development*, 63, 1266-1281.

Stevenson-Hindle, J., & Shouldice, A. (1995). Maternal interactions and self-reports related to attachment classifications at 4.5 years. *Child Development*, 66, 583-596.

Steward, R. J., Jo, H., Murray, D., Fitzgerald, W., Neil, D., Fear, F., & Hill, M. (1998). Psychological adjustment and coping styles of African American urban high school students. *Journal of Multicultural Counseling and Development*, 26, 2, 70-82.

Strayer, J., & Preece, C. (1999). Relations of self-evaluative emotional style to adult attachment and reported parenting. Paper presented at the annual meeting of the Canadian Pyschological Association, Halifax, Nova Scotia, May.

Tronick, E. Z. (1989). Emotions and emotional communication in infants. *American Pyschologist*, 44, 112-119.

Tuijman, A.C., & Keeves, J.P. (1997). Path analysis and linear structural relations analysis. In J.P. Keeves (Ed.), *Educational research, methodology, and measurment: An international handbook* (pp. 621-633). New York: Pergamon.

Yougblade, L., & Belsky, J., (1990). *Social and emotional consequences of child maltreatment*. In R. Ammerman & M. Hersen (Eds.), *Children at risk: An evaluation of factors contributing to child abuse and neglect* (pp. 109-146). New York: Plenum Pres.