

INTERORGANIZATIONAL RESPONSE NETWORKS IN FIGHTING AGAINST CRIME BY POLICE AGENCIES IN THE USA

Amerika Birleşik Devletleri'nde Polis Örgütlerinin Suçla Mücadelesinde Kurumlar Arası Müdahale Ağları

Ali ÜNLÜ*
Naim KAPUCU**

Özet

Kurumlar arası ağ Amerika Birleşik Devletleri'ndeki yerel polis birimleri tarafından suçla mücadelede yaygınlaşarak kullanılan bir yöntemdir. Yerel polis birimlerinin birbirleriyle bilgi paylaşımıyla kurulan kurumlar arası ağ, polisin karşılaştığı yetersiz bilgilenmeyi azaltmak amacıyla kullanılmaktadır. Gelişen bir alan olmasının yanında polis uygulaması ile diğer kamu kurumlarının uygulaması farklılıklar göstermektedir. Bu çalışmada, teorinin gelişimi, polis tarafından uygulanması ve teorinin uygulanabilirliği konuları tartışılmaktadır. Florida Dahili Bilgi Paylaşımı Ağı (FINDER) modeli ise teorinin uygulanışına bir örnek olarak incelenmiştir.

Anahtar Kelimeler: FINDER Programı, Organizasyonlar arası ağ, Asayiş, Birlikte Çalışabilirlik, Örgütsel Verimlilik.

Abstract

Interorganizational networks are increasingly used by local law enforcement agencies in response to crime in United States and elsewhere. Interorganizational networks help law enforcement to cope with the uncertainty of complex response operations in the local area by sharing information with other law enforcement agencies. While it is a developing field, its root in criminal justice is different from other public organizations. The study reviews the

* Doctoral Student at Public Affairs Department of College of Health and Public Affairs, University of Central Florida, aunlu@mail.ucf.edu

** Assistant Prof. Dr., University of Central Florida, Department of Public Administration, nkapucu@mail.ucf.edu

PBD, 11 (1) 2009, ss. 47-72

literature on networks (network theory) and implementation of the theory in law enforcement and interoperability issues were discussed. Florida Integrated Network for Data Exchange and Retrieval (FINDER) model was used as a case study for network model and information sharing in fight against crime.

Key Words: Interorganizational Network, Law Enforcement, Organizational Efficiency, Interoperability, FINDER Program.

Introduction

The primary function of the police is enforcing the law, detecting criminals, and bringing them to justice. The term ‘fight against crime’ aims to bring those goals in reality and protect citizens from crimes against property, violence, drug, and so on. Fight against crime, however, is getting more complex and more difficult for law enforcement agencies. Complexity does not only bring highly skilled personnel and technical investment to organizations, but also requires strong relationship with other law enforcement agencies.

For instance, the nature of dealing with organized crime is combination of an insufficient investigation information processing and a need for rapid decision-making. Organized crime groups work in wide range of environments and mobilize themselves and change according to activities and policy modifications of law enforcement agencies. Considering the fact that jurisdictional boundaries are one of the main obstacles, coordination of law enforcement organizations is inevitable to monitor activities of criminal groups in any jurisdiction.

The control of and participation into information has been developed with different concepts. Interorganizational network aims to increase organizational capacity through enabling access to resources of others by establishing networks. For example, the ‘structural hole’ concept from social capital theory, identifies the effectiveness and power of the brokerage opportunities (Burt, 2000). The concept proposes that there are gaps between nonredundant sources of information. Therefore, nonredundant contacts offer more additive information rather than overlapping information (Burt, 2000). If a police agency uses structural holes effectively, they can access useful information that can have impact on investigations and its capacity of quick decision making.

The geographic and demographic characteristics of jurisdictional areas have different impacts on crime rates and types. Law enforcement

agencies should have channel to adapt themselves to the ever changing environment. The big picture of the problem and integration of related information enable police to reduce crime rates. According to Kapucu, “the effective flow of information across organizational boundaries is critical for an organization’s ability to remain effective in a dynamic environment” (2006b:218). Hence, flow of and access to information is important predictors of law enforcement success in response to crime at both state and local level.

This study aims to identify how law enforcement agencies build and use information technology (IT) network systems as a part of the interorganizational network structure. The study also investigates whether or not information sharing has an impact on reducing crime rates. The focus of the paper is the structure and interoperability of interorganizational networks built among police agencies. The study answers the following research questions. How are the interorganizational networks established? What are the main elements of interorganizational networks? How do law enforcement agencies use IT and network systems in terms of coordination of information in criminal investigations? How does its structure affect interoperability? Especially, at local level, how can organizations build interorganizational network? Does interaction with other organizations affect their success? The research proposes that information sharing leads to both decrease in crime rates and increase the police enforcement. Florida Integrated Network for Data Exchange and Retrieval (FINDER) model will be utilized as a case study to see the implication of interorganizational network at the local level.

The primary contribution of this paper to the literature is that it shows interorganizational network theory is applicable in practice. Put differently, this paper will examine how far away the current local interorganizational networks from the theoretical concept are. The second purpose is that it will show how local agencies adopt their systems to the interorganizational network. What are the main concerns in building IT systems? How do they handle with economic cost of system adaptation?

1. Theoretical Review and Background Information

Globalization does not only facilitate the communication and shorten distances, but also accelerates all business entrepreneurship and criminal activities around the world. According to Scott (2003:281),

“developments in information technologies as well as the increasingly specialized nature of consumer markets have helped to create conditions favoring more flexible production regimes.” Criminal network is an extreme example of flexible entrepreneurship and diversity of groups; for instance, cocaine distribution chain begins from Colombian cartels through African criminals to Europeans.

The spread of communication technologies empowers the capabilities of organizations and individuals and give them more flexible management skill. Thus, loosely connected criminal organizations produce strong link among each other (Granovetter, 1973). This type of arrangement is characterized by a predominance of informal communicative relations, a horizontal as opposed to a hierarchical pattern of relations and a decentralized pattern of actors' positions, (Milward and Raab, 2002:417) which is difficult to be identified by law enforcement agencies. Interactions among criminal networks are characterized by thin connections and lack of trust. Therefore, they invest in erasing their trace after the transaction, or in legal form, crime. Their flexibility depends on sharing risk of arrestment and losing their goods/finance that are of value to them. Rather than business entrepreneurship, if both sides are willing to take equal risk and trust each other, bargaining or negotiation is easy step to make cooperation (Milward and Raab, 2002).

Information revolution improves activities of criminal organizations in static environment and with increased connectivity by communication and transportation technologies, their production increase in amount and in quality (McAllister, 2004). According to McAllister, “dynamic environments necessitate flexible information systems to ensure the organization's ability to adapt to ever-changing information flows. Agility then, is the goal of any business enterprise in the new economy” (2004:300). Therefore, it is not surprise to experience criminals' innovative collaboration with their counterparts while law enforcement agencies suffer from insufficient interorganizational cooperation.

It is getting tougher for both federal (central government in other settings) and local law enforcement agencies to respond to these criminal organizations. Without cooperation, policies do not give any hope for successful deterrence of organized criminal activities, such as terrorism and smuggling. Moreover, fight against non-organized criminals is getting more complex and cooperation in local level law enforcement agencies is necessary.

Figure 1: Networked Based Policy Puzzle

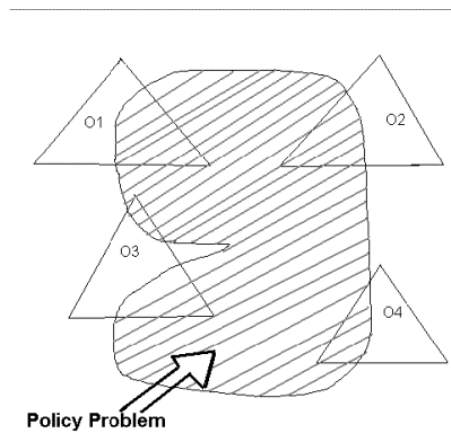

Source: Hjern, 1992:4.

For instance, if the crime as policy problem in a state, Figure 1 can be labeled drugs or terrorism or theft, and the governmental organizations could be labeled law enforcements, legislators, courts, and prisons. Hence, the power of strong policy requires recognition of the necessity of interorganizational response to those problems (Milward and Raab, 2002). It is obvious that problem is bigger than any single organization can handle; as a result, collaboration is inevitable for government organizations.

The criminal justice system encounters some problems such as inefficient manual processes, disparate or missing data, illegible index cards with seminal crime information, multiple and inconsistent incident/booking reports and uncoordinated relationships among justice agencies (Department of Justice (DOJ), 2002). As a result, offenders have remained free because agencies have not had the capacity to quickly and efficiently communicate with each other. It takes months and sometimes years to adjudicate and incarcerate suspects.

Difficulties in fight against crime are mostly related to environmental factors and organizational capacity to instant respond. Environment is an organization's dependency to the outside (Scott, 2003) because police

needs information, which is always outside of the agency. Most of the time spent in investigations is used for information gathering efforts. When information leads enough knowledge to collect strong evidence, police operations start. Therefore, information does not only affect investigations, but its availability and accessibility has direct impact on agencies' strategies and policies. Especially, local law enforcement agencies have limited access to data about criminal and registration records and residential information outside of their jurisdictional boundaries. Interorganizational network can provide law enforcement agencies with a structure to access important resources. Thus, environmental trends and external pressures led organizations to develop interorganizational networks (Bailey and Koney, 2000).

The success of the both criminal organizations and law enforcement depends how they use communication technologies and computer revolution. According to Milward and Raab (2002:20):

“Since information exchange and communication is a crucial precondition for integration and coordination, especially in networks that act globally, technological support is of great importance. The computer revolution and the distribution of modern communication technologies is generally seen as one of the reasons for the rise of the network society or the developing of Netwars”.

It is a new challenge for government decision makers to design and manage bureaucratic government with cross agency networks. All organizations, including government agencies, are under pressure to develop relationships outside their organizational boundaries because effective use of scarce resources depends on their ability to access them with limited sources. Considering the limitations of possession to that information internally, it is urgent that new technologies and policy innovations be developed. Therefore, it is of crucial importance to share data and access resources of other organizations to increase organizational power (Fountain, 2001).

The US government both at local and federal level has acknowledged the potential value of integrated information systems among law enforcement agencies for three decades (Rottman et al., 2007). Furthermore, the innovative use of information technologies is also seen as a best practice of government managers. For instance, 29% of the 'State and Local Government Awards' winners between 1990 and 1994 were awarded for utilizing IT in state and local governments in the

United States (Rottman et al., 2007). On the other hand, private and non-profit organizations also support criminal justice agencies to build integrated information systems. For instance, some computer services firms, such as IBM and Oracle, create special units that specialize in public safety and information sharing among agencies. The National Association for Justice Information System assists in development of definitions and coding standards for data repositories. The National Consortium for Justice Information and Statistics developed Justice Information Exchange Model to analyze justice information flows and document the related business process (Rottman et al., 2007).

It is also the part of the governance approach, which is believed to improve overall effectiveness and quality of the service by enhancing communication, establishing guidelines and policies, reducing turf battles, and fostering coordination and cooperation (DOJ, 2002). The new trend in management, governance, is conceptualized as “government by networks” (Moynihan, 2005:6). In particular, after the tragic events of September 11, 2001, it is clear that responding organizations failed because of insufficient communication and coordination infrastructures among each other (Kapucu, 2006). The US government perception on using IT systems has changed from a tool for increasing the convenience of government service provision, facilitating administrative reform and furthering democratic participation to a tool of defense against terrorist threats (Yıldız, 2007). Promotion of information sharing among agencies, merge and/or sharing of government databases are the most essential governmental projects to be improved and established between law enforcement agencies (Yıldız, 2007).

Consequently, the highly decentralized nature of law enforcement in the US impedes information sharing across jurisdictional boundaries, and even within the same jurisdiction. Current problems are not only complex and difficult to conceptualize and analyze but also interconnected. This complex and interdependent nature of the problems needs extensive collaboration (Kapucu, 2006). The current situation indicates that information sharing among law enforcement is the only way to achieve organizational goals. However, building interorganizational network is not as easy as it appears.

2. Interorganizational Networks

Interorganizational network is defined in this paper as “interorganizational networks are groups of legally separate organizations connected with each other through exchange relationships, common or complementary goals, and/or common bonds or social relationships that are sustained over time” (Williams, 2005). This structure has no “legitimate organizational authority to arbitrate and resolve disputes that may arise during the exchange” (Fountain, 2001:65). Most common interorganizational networks structures appear as joint ventures, business groups, franchises, research consortia, relational contracts and outsourcing agreements. It facilitates accessing to new technologies, sharing risks and innovations, coordinating exchanges and services (Scott, 2003; Chisholm, 1998). Connectedness provides governmental organizations with formal and informal relationships and capacity to succeed these goals. Currently, interorganizational collaboration has become more attractive due to functioning of many different types of organizations (Kapucu, 2005).

Besides a general metaphorical use, the term ‘network’ in this paper, it is also applied as an empirical tool to describe network structure, which will identify the governmental organizational structure in fight against crime. Secondly, the term network is used as a label for a specific type of network structure focusing on how organizations interact in local level with others. Thirdly, it is a concept to describe and analyze forms of governance, especially, forms of coordinating governance in state and local level. It also describes how leaders of these organizations promote or deter their agencies to interact with others (Milward and Raab, 2002). In the following section, building interorganizational network, its attractiveness, structure and its performance will be discussed.

2.1. Building An Interorganizational Network

Establishing a network is difficult task because technology is only part of the solution; legitimacy and conflict are the main obstacles (DOJ, 2002; Fountain, 2001). In particular, if the case is public issue, political and legal support at the top of the government is unavoidable. The legitimacy of interorganizational network depends on general legal authority over a governmental function, on specific legislation, or on formal executive directive (Eglene et al., 2007). Without support of elected political officials, establishing network across jurisdictional boundaries may face

several legitimacy problems. Well-defined and structured governance requires the cooperation of justice professionals and elected and appointed officials (DOJ, 2002).

Leaders of the organizations should involve in process when there is a conflict, they should solve it at the management level. Leaders have an important role for building interorganizational network as ‘facilitator or broker’ (Mandell and Keast, 2007), furthermore, top executives, as a grassroots effort, or by inter-local agency agreement officials, start most of projects in the US (DOJ, 2002). Leaders do not only play an essential role in securing political and executive support, but they also underpin building and maintaining relationships with other organizations, encourage learning and adaptation (Eglene et al., 2007). Although organizations make a consensus on network, they consider possible structural and management obstacles. After managerial consensus, integration requires people in local governments to adapt their processes to such systems.

Since such knowledge networks have a logical structure, it is usually not supported legally and therefore, participation is voluntary (Egnele et al., 2004). Moreover, Gulati and Gargiulo (1999) argue that interorganizational networks must be voluntary and need broad understanding of the problem. This kind of interorganizational networks will be different form than the ones in private sector. The key to the successful integration in America’s local law enforcement agencies clearly resides with their governance structure (DOJ, 2002).

There is no clear condition that discourages or promotes network formation (Fountain, 2001). It depends on “interaction among the external environment, the participating organizations, and the collaborative entity (from different stakeholder perspectives) as these networks evolve” (Fedorowicz et al., 2007:786). There are also barriers that prevent local law enforcement from integration. According to Department of Justice’s findings, lack of funding is the main barrier. On the other hand, it is a conditional situation, the size of their jurisdiction and budget are the predictor for funding necessity. For instance, funding is not the number one barrier by the smallest jurisdictions. Other identified barriers were technology issues (15%), staffing/personnel (14%), turf issues (14%), and political issues (11%) (DOJ, 2002).

2.2. The Role of Interorganizational Network

The reason of building network and the environment are the main determinants of network effectiveness. According to Oliver (1990, cited in Williams, 2005), six contingencies affect the formation of relationships between organizations. He suggests a comprehensive set of reasons why organizations enter and remain in interorganizational network. These are: to meet legal-political requirements (necessity), to reduce uncertainty in their environments (stability), to economize on transactions (efficiency), to pursue common or complementary goals (reciprocity), to gain credibility and respectability through association (institutional), and to preserve their autonomy (asymmetry).

The term network operates largely as abstract and conceptual system that enables members to perceive and understand large-scale problems in new ways (Williams, 2005). Networks help organizations to figure out these problems; what kind of trends do criminals use in what kind of environment; how do they use the jurisdictional differentiation; what are the organizations' roles; how can organization use information across boundaries and decide whether it is beneficial? Understanding large-scale problems and consensus on solution can combine all organizations in a network in the legal form due to necessity.

Interorganizational network also improves the ability of organizations to deal with ill-defined, complex problems or issues that individual organizations cannot handle alone (Williams, 2005). Dealing with criminals and criminal organizations by itself is enough for uncertainty. Connectedness reduces environmental uncertainty in interorganizational network structure, and facilitates information and vision sharing. Thus, interorganizational network supports stability and efficiency of organizations.

Sharing core technologies, such as database and other technological infrastructures, can also reduce governmental and organizational cost (Williams, 2005). Especially, data exchange with network has no cost after building it. Without network, the costs of office supplies, the shipping cost, the time for transaction are directly in the process, affecting agencies' performance. Thus, after networking, organizations can invest on their different needs. Members can meet from time to time to conduct activities required to carry out the higher-level system purpose. As not a centralized source of power, organizations are responsible for developing a vision, mission, and goals and for initiating

and managing work activities (Chisholm, 1998). It is also a training facility for leaders to share and learn visions, experience, and solutions.

Interorganizational network helps organization to overcome asymmetries. With network, agencies are part of the associations to increase their individual power in negotiations with government, unions and other interest groups, such as funding and granting institutions (Fountain, 2001). Being a member of the network also increases organizations' power. Networks in private sector provide organizations with the power to prevent competitor companies from market entry. Similarly, in public sector, networks as a source of information, skill, knowledge, and technology pool put organizations in a more advantageous position against their counterparts (Fountain, 2001).

2.3. Structure of Interorganizational Networks

Another consideration in building interorganizational network is whether the structure of interorganizational network affects its performance. Network and network structures are different terms; Keast et al., (2004) define network that it occurs "when links among a number of organizations or individuals become formalized. ...networks may involve simultaneous action by a number of different actors, but each is the action of an independently operating organization" (2004:364). On the other hand, network structure is "coming together to actively work on accomplishing a broad, common mission will goals be accomplished" (Keast et al., 2004:364). Feeling connected to each other decrease their independence and relinquishment from autonomy decrease to setup network structure.

Put it simple, unlike networks, in which people are only loosely linked to each other, in a network structure people must actively work together to accomplish that supposed to enhance government policy on a specific issue (Keast et al., 2004). Since interorganizational networks provide a structure to share information, this structure works in management mechanism. Networks management appears in two formats: informal (Bardach, 2001), and formal governance mechanisms and an explicit organizational structure (Milward and Provan, 2006).

According to Bailey and Koney (2000), there are four levels relationships among organizations, cooperation through coadunation;

they are based on organizations' relinquishment from some degree of autonomy and effort to join common purpose.

Cooperation: fully autonomous entities share information to support each other's organizational activities

Coordination: Otherwise, autonomous groups align activities, sponsor particular events, or deliver targeted services in pursuit of compatible goals.

Collaboration: parties work collectively through common strategies. Each relinquishes some degree of autonomy toward the realization of a jointly determined purpose

Coadunation: Member organizations unite within an integrated structure to the extent that one or more all relinquish their autonomy in favor of a surviving organization (2000:6-7).

Ties between these organizations explain what kind of relationships they made. In public organizations, full-integrated structure is desirable because it will contribute more to their effort. The closer to the coadunation stage, the higher the integration (Bailey and Koney, 2000) but more integration means more dependence and lower autonomy within the organizations.

The level of integration is important for organizations' survival and their access to government resources. According to Gray and Wood (1991), the success of interorganizational network relies upon identifying three broad areas of network development; correctly assessing the preconditions for forming a network, successfully negotiating the process, and thinking through the desired outcomes. Consequently, relinquishment from autonomy may not be easy because each member has different policies and different resources for fight against. If high level of organizational integration occurs, it will be possible under the political pressure, which may be the result of change in federal or state level policy. Otherwise, further integration among organization result in increase in formalization, such as new policies, procedures, contracts and laws (Bailey and Koney, 2000).

Maintaining stability and effectiveness of the organizations in complex environments can be achieved with flexible management model. McAllister (2004) argues that flexibility necessitates modeling, managing, and delivering a system that achieves the required integration. In complex and dynamic environments, uncertainty can be surpassed with flexible integration among organizations. However, establishing this kind

of model requires an extremely complex process of a great investment of time and capital.

2.4 Performance Measurement of Intergovernmental Networks

One of the difficulties in building interorganizational network is to define and measure the success of networks (Provan and Milward, 2001) because overlapping interactions between organizations enable both self-interest and common goals (Eglene, 2007). Therefore, the success of network should be measured at four levels: community, network, organization and individual (Eglene, 2007). At community level, the potential benefit to population is measured where the network serve. It is useful when service delivery to external clients matters. Nevertheless, in knowledge networks, the primary focus is internal use of network. In addition, the structure of the network (cooperative, coordinative, or collaborative) should be taken into consideration because the degree of relinquishment of autonomy shifts self-benefit toward common goals. Organizational and individual success may not appear in measurements (Mandell and Keast, 2007)

At network level, structure, performance and relationships of the interorganizational network are considered as relevant indicators of success. According to Eglene et al. (2007:96):

“Structural measurement includes the creation and maintenance of a network administrative structure, survival of the network beyond the tenure of the key individual participants, growth of membership, and network stability and resilience in the face of environment. Performance measurement have to do with such observable measures as the achievement of interim and long-term goals, integration and coordination of services to network members, growth in the knowledge content and use, and joint product development.”

It is known that few interorganizational networks succeed. The success depends on trust. Even at the building stage of the network, organizations test each other’s reputations for fairness and reliability. To secure trust among participants, they act norms (contract among actors) and implement sanctions against inappropriate actions. If they can manage trust in the long term, they can be successful (Fountain, 2001).

3. Interoperability and Interorganizational Network

The usability of the information is also important for interorganizational network. Furthermore, Katz and Lazer (2007) propose that network can be best understood how it offers an actor access to resources that make it more productive. To accept any knowledge network accountable, it should provide information at least about two things: ‘how to do things’ and ‘who knows how to do such things’ (Katz and Lazer, 2007). Therefore, bridging structural holes relies upon the ability of the system how it provides information and its interoperability.

Interoperability aims to provide basic standards that all government organizations can easily adopt and implement in their work processes. It is all about information systems and its usability by organizations or citizens in an integrated system (Juijarro, 2004). Interoperability has been identified as a major issue to be addressed by all e-government agencies. It is defined as an ability to exchange functionality and interpretable data between software entities (Movbray, 1995). The Commission of the Council and the European Parliament Communication adds business process to the definition and defines it as ‘ability of IT systems and of the business processes they support to exchange data and to enable the sharing of information and knowledge’ (2005).

“The concept has two features:

Application interoperability; which includes the communication issues, both at the telecommunications network access level and at the network interconnection level; and the distributed applications issues, regarding to the remote procedure call/method invocation mechanism and the public interface exportation/binding.

Semantic interoperability; which includes both data interpretation, by means of XLM schemas, and the knowledge presentation and exploitation, by means of ontologies and agents” (Juijarro, 2004:37).

Each participant has a different IT infrastructure, such as hardware and systems software that enable the applications to run. The adaptability of their systems and databases also affect the network structure and success of interoperability (Fedorowicz et al., 2007). Generally, interoperability is seen as a technical concept rather than political as in interorganizational networks. However, when it comes to connecting

many organizations especially from different sectors, such as health, public administration and law enforcement, other dimensions would matter, such as technical, semantic, social, cultural, economic, organizational and legal dimensions (Kubicek and Cimander, 2006).

Data protection is not only a security issue; it also enhances citizen's rights with regard to police data processing (Hert and Gutwirth, 2006). According to Herold, access to and sharing of each other's information in the justice realm should be governed by three guidelines or guarantees:

- “(1) Sharing should only be possible for law enforcement purposes;
- (2) The receiving party can only ‘get’ the information when he or she uses it for the purposes that have initially led to its gathering by the sending party;
- (3) The general principle of efficiency in state administration practice” (1978, cited in Hert and Gutwirth, 2003-).

Thus, interoperability standards for law enforcement agencies need special consideration because police data consist of security information, confidential data about personal records investigation information and many other kinds of secret information. Information should always be kept in original sources, police records should only be shared with police agencies and it is effectiveness includes administrative practices.

4. Florida Integrated Network for Data Exchange and Retrieval (FINDER)

To exemplify the application of interorganizational network to real situation, an interorganizational network within a state in the United States was selected. FINDER is the next generation of law enforcement information sharing technology. It is a cooperative effort between the Public Safety Technology Center at the University of Central Florida, and the Florida Law Enforcement Data Sharing Consortium. The FINDER network currently consists of 141 law enforcement agencies all through Florida. It is a developing public partnership between Law Enforcement agencies across the State of Florida and the University of Central Florida to combine current information technology tools and police operations requirements to achieve this interoperability goal. It aims to accomplish a

level of automated information exchange that will enhance the delivery of public safety services (Finder Guide, 2007).

Figure 2: FINDER Structure

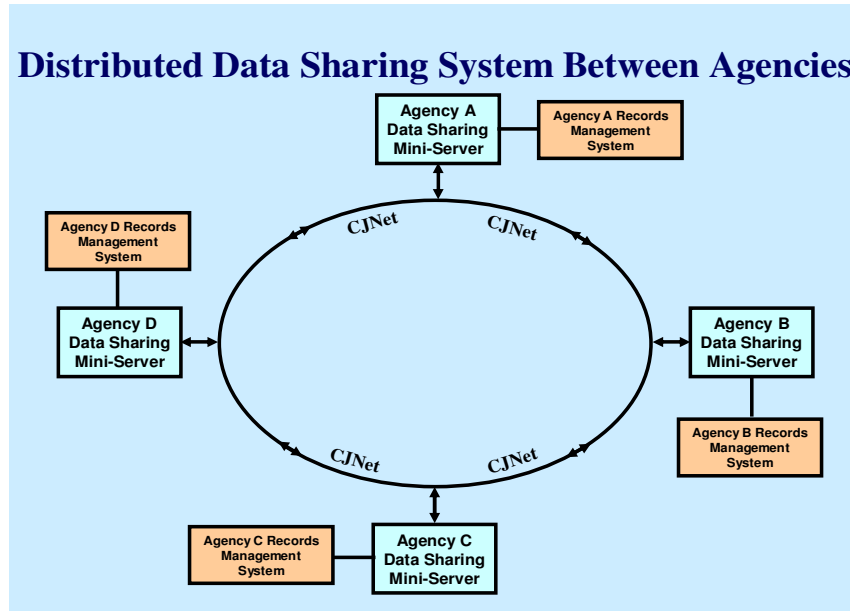

Source: Finder Guide, 2007.

Information sharing via IT systems has two main types: combining information in one centralized server (warehouse) or connecting data servers in organizations with network system (Rottman et al., 2007). While creating data warehouse is less costly, effective, more integrated and easier to develop, securing warehouse from hackers and legal framework are the main concerns. FINDER uses distributed data approach (Figure 2). In this approach, special middleware connects existing systems and it lets authorized users to access a variety of distributed database with a single query (Rottman et al., 2007).

In FINDER structure, organizations may use many different types of information management systems. Nevertheless, each agency should maintain a data-sharing server that uses the Florida Department of Law Enforcement's secure CJNet intranet to provide a web services interface to the data they wish to share. Agencies can then send distributed queries to other agencies, and the system formats the response and returns it in a consolidated report. This distributed data accessibility provides

authorized access to existing agency information resources. Control of the data remains with the originating agency, yet this distributed system allows the agency to share that information with other law enforcement entities (Finder Guide, 2007). FINDER currently provides three types of information; pawn data (pawnshop transactions, transports), persons and vehicles data (incident reports, accident reports, traffic citations, field interrogations & contacts, etc.). The goal of the system is to create effective data sharing platform, which has become even more crucial in this era of increased domestic security concerns (Finder Guide, 2007).

The most significant feature of interoperability of the system is providing mass data related to persons, property and vehicles that facilitate investigations. With this distributed approach, the authorized requestor is merely accessing data that is already contained in various agency record management systems (Finder Guide, 2007). The consortium is guided by a steering committee that is comprised of a representative from each of the member agencies. The steering committee provides direction and maintains oversight of the project and all of its endeavors (Finder Guide, 2007). Member agencies manage the consortium with a vote on the steering committee. They set dues, establish policies, and determine development priorities. All Consortium resources are shared and freely available to all members.

5. Discussions

Interorganizational networks in response to crime within the legal system are more about politics rather than technology (Potter et al., 2004) and FINDER achieved this process successfully. It is not mandatory to participate into network but most of the law enforcement agencies are member of the FINDER. It is still a developing project but network was established with strong stakeholders. The significant point of the project is that all the main figures are local organizations. University of Florida as a technical provider connects bigger organizations and these champion organizations encourage small organizations to be part of the network. Particularly if we look at the member organizations' distribution in the map (Figure 3), the closer to the University of Central Florida (UCF), the more likely police organizations are part of the network. Even this project is supported by State and Federal funds; the power of local interaction is still dominant element in this network. Put it differently, the importance

of local connectedness also facilitates building interorganizational networks.

Figure 3: FINDER Participants

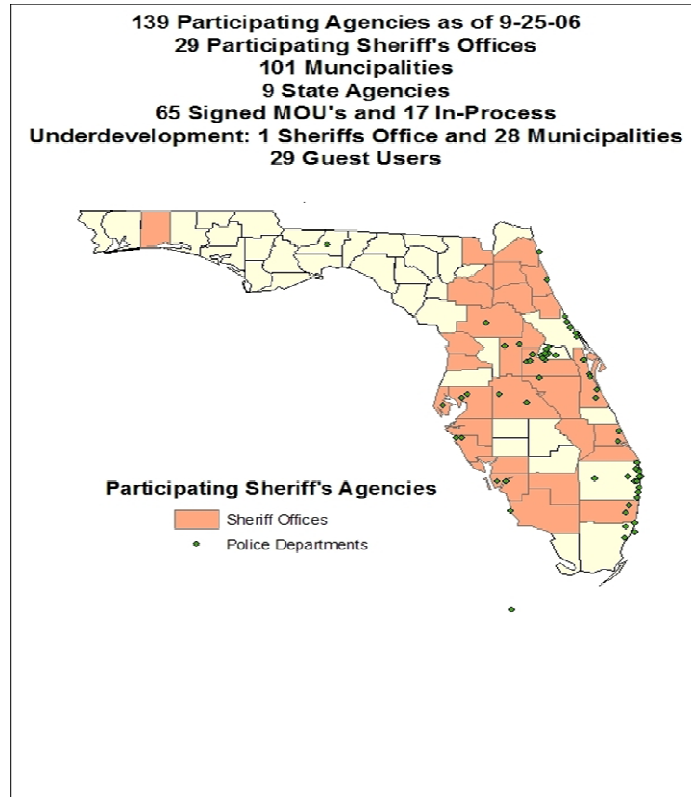

Source: Finder Web Page, 2007

In interoperability perspective, FINDER successfully fit with Herold (1978, cited in Hert and Gutwirth, 2003) standards, firstly, sharing is only possible for law enforcement purposes. Secondly, the receiving party can only 'get' the information when he or she uses it for the purposes that have initially led to its gathering by the sending party. If any party leaves the network, no one can access that available information. Information is only available if the agency is a member of the network. The general principle of efficiency in state administration practice and overall contribution is beneficial for state.

While software connects data servers, each department can use different applications. 'Plug and play' feature of the system is a critical strategy for local agencies to build their own system based on their budget (Potter et al., 2004). FINDER gives this flexibility, except one server, each agency uses their own system for data input, data record and so on. Therefore, the structure of network is flexible and has a lower cost, which may also accelerate adaptation of the network.

The software has the ability to increase the interoperability of the system whatever the organizations system is and it is developed by university. Therefore, there is no additional cost to police organizations. While funding is the main obstacle to interorganizational networks, FINDER reduces the cost to expected participants and encourages police agencies to be member without budget problems. Compared to other network projects, FINDER is one of the cheapest networks that requests lowest member fee. While funding is the first obstacles on building network systems, FINDER eliminates main obstacles. For instance, agencies up to 500 sworn officers should pay \$7500 annually (Finder Guide, 2007). Eliminating funding issues may facilitate building interorganizational network between public organizations in local level.

On the other hand, each department shares different level of information. There is no formal requirement about how much information they have to share. While three types of information - pawn, vehicle and personal- are commonly shared, if any organization wants to share only vehicle records, there is no restriction. Therefore, with limited data sharing, they can access all other organizations' data. It is still unknown whether it is a legal or technical issue but in the long run, this kind of implication will affect trust in network. As mentioned above, formal norms and sanctions are necessary to ensure trust and stabilize network in the long term. Developing nature of the FINDER inhibits taking formal rules and sanctions to strength network for possible threats against trust. Maybe at the beginning of the process, organizations do not consider so much about sanctions and norms but the stability of the system. Therefore, debates and discussion about the design of the network ensure enough trust among organizations and the level of trust is enough to stabilize the system.

FINDER promotes law enforcement agencies to access information across the jurisdictional boundaries. However, three types of data exchange may not enough to attract other agencies to participate. Police

collect wide range of data to use for investigations and intelligence purposes. It may vary from criminal case details, fingerprint to police calls, residential information data. The more shared data will lead to more attractive network. Its development depends most likely on trust and technological adaptation.

It is still unknown how effectively officers use FINDER. Technically and semantically, software provides enough interoperability to officers. Based on available data, they can access data; however, information standards may vary. Each agency may use different standards for data input, for instance, counties may use different residential record input and this variability may affect officers' judgment. Some of them may be comfortable with some departments' data and some of them may not. While accessing information may be possible technically, the perception of officers is very important. It is still unknown how the FINDER user friendly is, how officers use FINDER in daily basis and whether they feel comfortable when they use it. When network's interoperability becomes attractive, officer will more likely to use it and the more they use, the more they can benefit.

The main point is whether interactions with other organizations affect their success? According to Jian et al (2007), any network project at least achieves the requirements of: 1) being transformable to state level information standards; 2) having a positive impact on existing systems; 3) being easy to implement and deploy; and 4) being compliant with current laws and regulations. It is clear that with some weaknesses, FINDER has achieved these requirements. For instance, in the last 90 days of 2005, detectives filed 257 reports of success using this system. Within these success reports were 140 arrests and the recovery of \$139,282 in stolen property (Finder Guide, 2007). The number of members is still growing, members still give commitment to the system and there is no leave out at all. The system works well, university is still working on software, and they released 4.0 versions, which meaning that reasonable development can be measured. The content of the information is growing, at the beginning of the project, system only provided two types of information and currently one more types of information is available.

Finally, the structure of the network is the weakest one in terms of their relinquishment from their autonomy and working around common goal. Their structure best fits to cooperation, "fully autonomous entities share information to support each other's organizational activities" (Bailey and Koney, 2000:6-7). To fight against a specific crime such as

illegal drug or terrorism in state level, their connectedness level should be more close to each other. However, it must be considered how much complex to gather them together, and also structure cohesion takes time to build stronger interorganizational network.

Information Technology is getting more important in law enforcement. Nevertheless, law enforcement agencies typically lack the type of technologies, equipment and connections necessary to provide beat officers with network access to information while they are in the field. According to field experts (Blumberg, 2005):

“Giving officers the ability to look at photos will give them a better idea if the person they're talking to is the person they're looking for. It also will give them the access to critical data that will enable them to make the best decisions. It will save us all time, money and effort, and the officer's safety will be preserved”

In the future, networks will be the key for success because sharing information even at individual level will facilitate officers' job. For instance, using mobile devices to access information will also contribute to the community because recently, "officers were spending a good 34 percent of their workday sitting at a desk out of touch with the community" (Blumberg, 2005). Using appropriate technology to support police officers with usable information clearly affects police performance.

Conclusion

Interorganizational network is a strong managerial tool to use resources efficiently. Both administrative and technological support is inevitable to build network system. Our major finding shows that data sharing is still a developing concept among local law enforcement agency in the United States and initial attempts are not strong as desired. While interorganizational networks attract politicians, administrators, and citizens, the legal framework, funding and administrative support are main obstacles to spread interorganizational networks among law enforcement agencies.

When systems are established, its interoperability will be matter but currently there is not enough information to test systems' interoperability. It is most likely considered only as technical capability, but to use it effectively, perception of officers is very important. If officer feel

comfortable when they use it and find it practical then using the system may become a daily habit.

References

- Abadinsky, Howard, (2003), *Organized Crime*, Belmont: Wadsworth Publishing, 7. Edition.
- Bailey, Darlyne and Koney, Kelly McNally, (2000), *Strategic Alliances among Health and Human Service Organizations, From Affiliations to Consolidations*, California: Sage Publications Inc. Thousand Oaks.
- Barabasi, Albert-László, (2002), *Linked: The New Science of Networks*, Cambridge: Perseus Publishing.
- Bardach, Eugene, (2001), “Developmental dynamics: Interagency collaboration as an emergent phenomenon”, *Journal of Public Administration Research and Theory*, 11/2, pp.149–164.
- Bruinsma, Gerben and Bernasco, Wim, (2004), “Criminal Groups and Transnational Illegal Markets: A More Detailed Examination On The Basis of Social Network Theory”, *Crime, Law & Social Change*, 41, pp.79–94.
- Burt, Ronald S., (2000), “The Network Structure of Social Capital”, in R. Sutton & B. Staw (Eds.) *Research in Organizational Behavior*, Westport: CT. JAI Press.
- Carley, Kathleen M. and Harrald, John R., (1997), “Organizational Learning under Fire, Theory and Practice”, *American Behavioral Scientist*, 40/3, pp.310-332.
- Chisholm, Rupert F., (1998), *Developing Network Organizations: Learning from Practice and Theory*, New York: Addison - Wesley Publishing.
- Department of Justice, Bureau of Justice Assistance (DOJ), (2002), *Mission Possible: Strong Governance Structures for the Integration of Justice Information Systems*. Retrieved on November 21, 2007 from <http://www.ncjrs.gov/pdffiles1/bja/192278.pdf>
- Eglene, O'neill; Dawes, Sharon S. and Schnider, Christian A., (2007), “Authority and Leadership Patterns in Public Sector Knowledge Networks,” *The American Review of Public Administration*, 37/1, pp.91-113.

- Fedorowicz, Jane; Gogan, Janis L. and Williams, Christine B., (2007), "A Collaborative Network for First Responders: Lessons from the CapWIN case", *Government Information Quarterly*, 24, pp.785–807.
- Field, John, (2003), *Social Capital*, New York: Routledge.
- Finder Guide, (2007), "Law Enforcement Data Sharing Consortium Information Guide", Retrieved on November 21, 2007 from <http://finder.ucf.edu/Documents/tabid/64/Default.aspx>.
- Fountain, Jane E., (2001), *Building the Virtual State: Information technology and Institutional Change*, Chapter 5, Washington DC: Brookings Intuition Press. pp. 64-82.
- Granovetter, Mark S., (1973), "The Strength of Weak Ties," *American Journal of Sociology*, 78, pp.1360-1380.
- Gray, Barbara, (1989), *Collaborating*, San Francisco: Jossey_bass Inc.
- Guijarro, Luis G., (2004), "Analysis of the Interoperability Frameworks in e-Government Initiatives", R Traummuller (Ed.) *EGOV 2004*, LNCS 3183. pp. 36-39
- Gulati, Ranjay and Gargiulo, Martin, (1999), "Where Do Interorganizational Networks Come From?," *AJS*, 104/5, pp.1439–93.
- Halpern, David, (2005), *Social Capital*, Malden: Polity Press.
- Hert, Paul De and Gutwirth, Serge, (2006), "Interoperability of Police Databases within the EU: An Accountable Political Choice?," *International Review of Law Computers & Technology*, 20/1&2, pp.21–35.
- Hughes, Lorine A., (2005), "Studying Youth Gangs: Alternative Methods and Conclusions", *Journal of Contemporary Criminal Justice*, 21/2, pp.98-119.
- Jian, Wen-Shan; Hsu, Chien-Yeh; Hao, Te-Hui; Wen, Hsyien-Chia; Hsu, Min-Huei; Lee, Yen-Liang and Li, Yu-Chuan, (2007), "Building A Portable Data And Information Interoperability Infrastructure-Framework For A Standard Taiwan Electronic Medical Record Template", *Computer Methods and Programs in Biomedicine*, 88, pp.102–111.

- Kapucu, Naim, (2005), "Interorganizational Coordination in Dynamic Context: Networks in Emergency Response Management," *Connections*, 26/2, pp.33-48.
- Kapucu, Naim, (2006a), "Public-Nonprofit Partnerships for Collective Action in Dynamic Contexts of Emergencies," *Public Administration*, 84/1, pp.205-220.
- Kapucu, Naim, (2006b), "Interagency Communication Networks During Emergencies: Boundary Spanners in Multiagency Coordination," *American Review of Public Administration*, 36/2, pp.207-225.
- Katz, Nancy and Lazer, David, (2007), *Building Effective Intra-Organizational Networks: The Role of Teams*, Retrieved on November 25, 2007 from www.ksg.harvard.edu/~davidlazer/files/papers/Lazer_Katz_Building_Effective.pdf.
- Keast, Robyn; Mandell, Myrna P.; Brown, Kerry and Woolcock, Geoffrey, (2004), "Network Structures: Working Differently and Changing Expectations," *Public Administration Review*, 64/3.
- Kelly, Robert J.; Smith, Eugene F.; Maghan, Jess and Serio, Joseph, (2005), *Illicit Trafficking*, Santa Barbara: ABC-CLIO Inc.
- Kenney, Michael, (2007), *From Pablo to Osama: Trafficking and Terrorist Networks, Government Bureaucracies, and Competitive Adaptation*, University Park: Pennsylvania State University Press.
- Kubicek, Herbert and Cimander, Ralf, (2005), "Interoperability in Government. A Survey On Information Needs of Different EU Stakeholders", *European Review of Political Technologies*, 3:1-17, Retrieved on November 22, 2007 from http://www.politech-institute.org/review/articles/KUBICEK_Herbert_&_CIMANDER_Ralf_volume_3.pdf.
- Mandell, Myrna and Keast, Robyn, (2007), "Evaluating Network Arrangements toward Revised Performance Measures," *Public Performance & Management Review*, 30/4, pp.574-597.
- Mcallister, Brad, (2004), "Al Qaeda and the Innovative Firm: Demythologizing the Network," *Studies in Conflict & Terrorism*, 27, pp.297-319.

- Milward, H. Brinton and Provan, Keith G., (2006), "A Manager's Guide to Choosing and Using Collaborative Networks," Report published by the IBM Center for the Business of Government, Washington, DC.
- Milward, H. Brinton and Raab, Jörg, (2002), "Dark Networks: The Structure, Operation, and Performance of International Drug, Terror, and Arms Trafficking Networks," Paper presented at the International Conference on the Empirical Study of Governance, Management, and Performance Barcelona, Spain, 4-5 October 2002.
- Moynihan, Donald P., (2005), "Leveraging Collaborative Networks in Infrequent Emergency Situation," Washington DC: IBM the Center for the Business of Government. <http://www.businessofgovernment.com/pdfs/MoynihanReport.pdf> [accessed online on January 23, 2008].
- Mowbray, Thomas J. and Zahavi, Ron, (1995), *The Essential CORBA: Systems Integration Using Distributed Objects*. New York: John Valley & Sons
- Provan, Keith G. and Milward, H. Brinton, (2001), "Do Networks Really Work? A Framework for Evaluating Public-sector Organizational Networks," *Public Administration Review*, 61, pp.414-423.
- Provan, Keith G. and Milward, H. Brinton, (2004), "Cooperation and Compromise: A Network Response to Conflicting Institutional Pressures in Community Mental Health, Nonprofit and Voluntary Sector," *Quarterly*, 33/ 3.
- Provan, Keith G.; Veazie, Mark A.; Staten, Lisa K. and Teufel-Shone, Nicolette I. (2005), "The Use of Network Analysis to Strengthen Community Partnerships," *Public Administration Review*, 65/5.
- Rottman, Joseph W.; Smith, L. Douglas; Long, David A. and Crofts, Chuck, (2007), "Implementing Judicial Management Systems Within an Integrated Justice Information Framework A Case Study on Information Systems Development in the Public Sector," *The American Review of Public Administration*, 37/ 4, pp.436-457.
- Scott, W. Richard, (2003), *Organizations; Rational, Natural, and Open Systems*, Fifth Edition, New Jersey: Pearson Education, Inc.

Williams, Trevor, (2005), "Cooperation by Design: Structure and Cooperation in Interorganizational Networks," *Journal of Business Research*, 58, pp.223– 231.

Yıldız, Mete, (2007), "E-government research: Reviewing the literature, limitations, and ways forward", *Government Information Quarterly*, 24, pp.646-665.